

DYWIDAG Geotechnical Systems

DYWIDAG Soil Nailing System with Hollow Bars

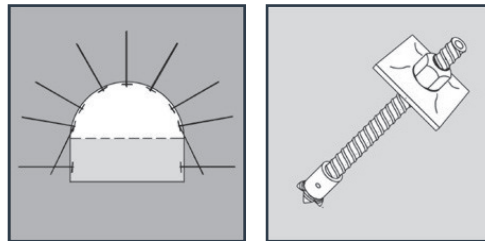

**DYWIDAG Soil Nailing System
with Hollow Bars Type R32N**

Approval Number

Z-34.13-208

Validity

21 April 2004 - 30 April 2014

DEUTSCHES INSTITUT FÜR BAUTECHNIK

(German Institute for Civil Engineering)

Statutory Body

Notification

about the amendment and extension of validity of the approval certificate issued on

April 21st, 2004

Approval office for construction products and construction
Testing office for structural engineering
Member of the European Organization for Technical Approvals and of the European Union for Agrément in construction UEA tc

Phone: +49 30 78730 - 0
Fax: +49 30 78730 - 320
E-Mail: dibt@dibt.de

Date: May 25th, 2009
Reference No.: II 25-1.34.13-11/08

Approval Number:

Z-34.13-208

Applicant:

DYWIDAG-Systems International GmbH
Dywidagstraße 1
85609 Aschheim

Object of Approval:

DYWIDAG Soil Nailing System with hollow bars type R32N

Valid until:

30 April 2014

This notification amends and extends the validity of the approval certificate issued on April 21st, 2004. This notification comprises three pages. It is only valid in conjunction with the aforementioned approval certificate and may only be used in conjunction with it.

Important Notice

The notification in hand is the translation of a document originally prepared in German language which has not been verified and officially authorized by the "Deutsches Institut für Bautechnik" (German Institute for Civil Engineering). In case of doubt in respect to wording and/or interpretation of this approval, the original German version of this document shall prevail exclusively. Therefore, no liability is assumed for translation errors or inaccuracies.

II. SPECIAL PROVISIONS: amendments

The special provisions of this approval are amended as follows.

1 Section 3 contains the following version:

3 Provisions for Planning and Design

3.1 General

For the planning and design of structures using soil nails, the following provisions must apply:

3.2 Internal and External Stability of the Nailed Soil Body

The following stability proofs must be carried out:

- Slide stability within and underneath the nailed soil body as specified by DIN 1054 : 1976-11 (see Figure 1, Appendix 1),
- evidence that the force resulting from constant loads cuts the sole area in its core (stability against tilting; see Figure 1, Appendix 1),
- ground failure safety (see Figure 1, Appendix 1): evidence must be produced in accordance with DIN 4017:1979-08,
- testing of the sliding body (see Figure 2, Appendix 1).

The least favourable position of the sliding line is to be determined deviating from DIN 4084:1981-07 by variation of angle ϑ . Active loads from soil pressure, the weight of the nailed soil body and external loads must be taken into account in the sliding bodies to be varied. These loads are counteracted by resistive forces from friction and cohesion in the sliding line as well as restraining forces of the nail sections located outside the sliding body (cf. section 3.3).

The counteraction of resistive and active loads must result in a safety factor of

$$\eta \geq 2.0 \text{ (load case 1 according to DIN 1054:1976-11)}$$

$$\eta \geq 1.5 \text{ (load case 2 according to DIN 1054:1976-11).}$$

If evidence is produced in accordance with the Fellenius rule

$$\eta_r = \frac{\tan cal\varphi}{\tan erf\varphi}$$

the safety factor is

$$\eta_r \geq 1.4 \text{ (load case 1 according to DIN 1054:1976-11)}$$

$$\eta_r \geq 1.3 \text{ (load case 2 according to DIN 1054:1976-11).}$$

These examinations are to be carried out for

- the construction levels significant for stability based on the safety requirements of load case 2,
- the final state of the structure with regard to the base joint (resp. for sliding bodies starting from the base joint) and with regards to the intermediate joints significant for stability (or sliding bodies starting from them) based on the safety requirements of load case 1.

For low-lying joints, additionally evidence of the

- stability against gliding as required by DIN 1054:1976-11 and
- safety against failure of the ground as stipulated by DIN 4084:1981-07

shall be proven if the ground underneath the nailed soil body has lower shear strengths. If necessary, these evidences must also be produced for construction levels.

3.3 Verification of the Nails

The evidence which results in the greatest nail loads is decisive for the dimensioning of the nails. For this purpose, the following examinations must be carried out:

- Load portions in the nails based on the testing of the sliding body for final state or construction levels (see section 3.2),
- Load portions in the nails from the active soil pressure on the facing (see section 3.4).

Evidence must be produced that a nail force of 131 kN (= yield load/1.75) is not exceeded and that loads from the nail can be transferred into the ground with a safety factor of 2.0 (see section 4.7).

The following values must be assumed:

- yield load: 230 kN
- ultimate capacity: 280 kN

When calculating nail forces, it must be demonstrated that the change of force in the steel tendon due to frequently repetitive live loads (including wind) based on the dynamic behavior of the air-side anchorage and the splices in the steel tendon does not exceed a value of 22 kN.

3.4 Facing

The soil pressure acting on the facing from the nailed soil body may be assumed to be 0.85 times the value of the active soil pressure in accordance with Coulomb's theory, but without taking into account any cohesion. The active soil pressure may be calculated as a rectangular distribution. Even if the soil is stratified, the overall soil pressure may be considered to be uniform. Active soil pressures from local loads and loads from ground anchors must not be reduced. The wall friction angle is to be specified with $\delta = 0$.

The dimensions of the facing must comply with DIN 1045-1:2008-08. Near the nail heads, evidence against punching and partial pressure must be produced in accordance with DIN 1045-1:2008-08.

3.5 Deformations

Horizontal movements of 2 ‰ to 4 ‰ of the wall height have been measured for this type of construction in tests under dead weight. In those tests, the lengths of the nails were 0.5 to 0.7 times of the wall height. If deformations must be restricted, the safety factors defined in section 3.2 must be increased.

In addition, the following reliable deformation values must be considered for the coupling joints or end anchorages of the soil nails:

- slip: 0.5 mm for each coupling joint or end anchorage,
- indentation of the domed plate: 5 mm.

(These values are valid for a permissible nail load of 131 kN.)

DEUTSCHES INSTITUT FÜR BAUTECHNIK

(German Institute for Civil Engineering)

Statutory Body

10829 Berlin, 21 April 2004
Kolonnenstrasse 30 L
Phone: 030 78730-317
Fax: 030 78730-320
Ref No.: II 32-1.34.13-4/03

APPROVAL CERTIFICATE

Approval Number:

Z-34.13-208

Applicant:

DYWIDAG-Systems International GmbH
Dywidagstraße 1
85609 Aschheim

Object of Approval:

DYWIDAG Soil Nailing System with hollow bars type R32N

Valid until:

30 April 2009

The aforementioned object of approval is herewith generally approved by the construction supervision authority in accordance with German building legislation.

This approval certificate comprises eleven pages and five appended sheets.

Important Notice

The approval in hand is the translation of a document originally prepared in the German language which has not been verified and officially authorized by the "Deutsches Institut für Bautechnik" (German Institute for Civil Engineering). In case of doubt in respect to wording and/or interpretation of this approval, the original German version of this document shall prevail exclusively. Therefore no liability is assumed for translation errors or inaccuracies.

I. GENERAL PROVISIONS

- 1 This approval certificate furnishes proof of the usability and applicability of the object of approval as stipulated by the state building regulations.
- 2 This approval certificate does not replace any permits, licences and certificates required for the execution of construction projects by German law.
- 3 This approval certificate is granted without prejudice to third party rights, in particular private property rights.
- 4 Notwithstanding any further regulations in the "Special Provisions" section, the manufacturer and distributor of the object of approval shall provide the user with copies of the approval certificate; furthermore, they shall inform the user that the approval certificate must be available at the place of use. Copies of this approval certificate must be submitted to all authorities involved on request.
- 5 This approval certificate may only be copied in its entirety. The publication of excerpts requires the consent of the German Institute for Civil Engineering. Texts and drawings in advertising material must not contradict the approval certificate. Translations of the approval certificate must contain the following notice: "Translation of the German original which has not been certified by the German Institute for Civil Engineering".
- 6 This approval is not granted irrevocably. The provisions of this approval may be amended or modified later, in particular, if new technical findings should require so.

II. SPECIAL PROVISIONS

1 Object of Approval and Application Range

1.1 General

Object of the following approval is the DYWIDAG Soil Nailing System with hollow bars type R32N. The nailing of soil bodies must be performed using soil nails and a facing in the manner shown in the appendices by taking into account the following provisions. Nailing increases the tensile and shear strengths of the soil such that the nailed soil body may be regarded as a monolithic block and verified as such. The facing does not need to be embedded underneath the bottom of the building excavation. The minimum length of the soil nails follows from the evidence of stability in accordance with section 3. The maximum distance between the nails is 1.5 m in the horizontal and vertical direction and may only be exceeded if the three-dimensional stability has been verified.

1.2 Area of Application

1.2.1 Structural Measures

The DYWIDAG Soil Nailing System with hollow bars type R32N may be used for temporary (≤ 2 years) applications to secure abrupt topographical changes, e.g. excavations and tieback walls, secure existing slopes and stabilize earth bodies subjected to loads during underpinning works at any angle.

1.2.2 Soil Types

Soil nailing may be used in non-cohesive and cohesive soils as specified by DIN 1054:2003-01, paragraphs 5.2.2 and 5.2.3, and in rock, if the rock behaves like unconsolidated material with regard to soil mechanic analysis. Soil nailing must not be carried out, if the soil or the groundwater contains substances which attack concrete (cf. DIN 4030). If the sulphate content of the soil or the groundwater is slightly corrosive as specified by DIN 4030-1:1991-06 - Assessment of Waters, Soils and Gases attacking Concrete; Basics and Threshold Values -, Tables 4 and 5, soil nails may be installed, provided that cement with a high sulphate resistance is used.

1.3 Soil investigation

In accordance with DIN 1054 soil investigations required for support structures must be carried out and evaluated under the direction of an expert in earth construction and foundation engineering. It must also be examined whether the exposed soil is temporarily stable at the intended depth of excavation. The soil must not break up if the facing is formed by shotcreting.

2 Provisions for the Building Product

2.1 Properties and Composition

2.1.1 Steel Tendon

For the steel tendon max. 3.0 m long, seamless pipes made of steel 28Mn6 as stipulated by DIN EN 10 083-1 must be used, on which a continuous left-hand thread is cold-rolled in accordance with ISO 10 208 (see Appendix 2).

The tendons must not be welded.

The steel pipe also serves as a drill rod when drilling the boreholes.

2.1.2 Corrosion Protection and Fabrication of the Soil Nail

The steel tendons should be encased with 20 mm thick cement grout cover; the minimum cover must be ≥ 15 mm. Pursuant to Appendix 4, the steel tendons must be provided with spacers at intervals of ≤ 3 m.

2.1.3 Air-Side Anchorage

The steel tendons must be anchored using nuts made of cast steel GS-34 CrMo4 (DIN 17 205) according to Appendix 4 and plates made of S235 (DIN EN 10 025) according to Appendix 5. If due to the construction process small drilling or other constructional deviations are to be expected, domed plates as shown in Appendix 5 must be used. The tendon must be anchored perpendicular to its axis in each direction. The transfer of forces in the facing (e.g. splitting forces) must be verified on a case-to-case basis (see also section 3.4).

The values indicated in Section 3.5 for the slip on the end anchorage and the indentation of the domed plate must be taken into account.

2.1.4 Coupler Splices

According to Appendix 4, the steel tendons must be spliced through couplers made of steel 28Mn6 (DIN EN 10 083-1).

Steel tendon and coupler are to be tensioned against each other using a torque of 300 to 500 Nm.

Slip values per coupling as given in section 3.5 have to be regarded.

2.1.5 Spacers

One spacer made of cast steel GS-34 CrMo4 as stipulated by DIN 17 205 or, alternatively, cast steel EN-GJS-500-7 as required by DIN EN 1563 is to be positioned in the region of each coupler according to Appendices 3 and 4.

2.2 Storage, Transport and Labelling

2.2.1 Storage and Transport

The steel tendons must be stored and transported in dry conditions. They must be protected against damage, dirt accumulation and humidity. They must be clean and free of damaging rust. Steel tendons with a slight rust film may be used. "Slight rust film" is defined as the uniform beginning of rust formation which has not yet led to the formation of corrosion pits discernable with the naked eye and which, in general, may be removed by wiping with a dry rag. The means of transport and storage rooms for steel tendons must be free of any substances which may cause or benefit corrosion (e.g. chlorides, nitrates, acids etc.).

Damaged steel tendons must not be used.

2.2.2 Labelling

The manufacturer has to mark the delivery note for nail components stipulated for installation and grouting with the conformity symbol (Ü-Zeichen) pursuant to the conformity symbol regulations issued by the German States. Labelling may only be carried out, if the requirements pursuant to Section 2.3 have been met.

Among other things the delivery note must indicate for which soil nails the components are determined and in which factory they have been produced.

2.3 Evidence of Conformity

2.3.1 General

Based on an in-house production inspection and a regular external supervision including first testing, every fabricating plant must comply with the following provisions to confirm conformity of the nail components with the provisions of this approval certificate.

The manufacturer of the nail components shall commission a recognized certification institution and a recognized inspection agency to issue the certificate of conformity and perform the external surveillance including the inspection of products.

The certification institution must submit a copy of the issued certificate of conformity to the German Institute for Civil Engineering for information.

In addition, the German Institute for Civil Engineering is to be provided with a copy of the report on the first testing for information.

2.3.2 In-house Production Control

In every fabricating plant an in-house production control must be established and implemented. By "in-house production control" the continuous monitoring of the production by the manufacturer is understood which ensures that the manufactured building products comply with the provisions of this approval certificate.

For the monitoring the processing instructions filed with the German Institute for Civil Engineering must be taken into account.

The results of the in-house production control must be recorded and evaluated. The recordings must at least include the following information:

- Description of the building product or of the basic material, respectively, and its components,
- nature of the control or inspection,
- dates of manufacture and inspection of the building product or of the basic material, respectively, or its components,
- results of the controls and inspections and, if applicable, comparison with the requirements,
- signature of the person in charge of the in-house production control.

The records must be kept for at least five years and submitted to the inspection agency commissioned for external surveillance. On request, they are to be presented to the German Institute for Civil Engineering and the competent supreme construction supervision authority.

In the case of insufficient test results, the manufacturer shall immediately take the necessary actions to remedy the defect. Building products which do not meet the requirements are to be handled in a way that excludes any confusion with complying products. After the defect has been remedied, the corresponding test is to be immediately repeated – as far as technically feasible - to prove removal of defects.

The in-house production control should at least include the following measures:

2.3.2.1 Steel Tendon

Evidence of condition related properties of the steel pipe made of steel 28Mn6, material no. 1.1170, as required by DIN EN 10 083-1 used for the fabrication of the tendon must be produced with inspection certificate "3.1.B" in accordance with DIN EN 10 204:1995-08.

In addition to the examinations stated hereinafter, the applicant must control the material characteristics of the basic material on a test basis.

After the thread has been rolled on, the applicant must carry out the following examinations for each production batch:

Those steel tendons which have been fabricated from one melting charge and on one thread rolling machine in one calendar week at the most are to be considered as a production batch. The weight of the batch may not exceed 10 t. At least one tensile specimen must be taken from each batch at random and examined.

The examination of the tensile specimen must include: the weight relative to the length, the thread geometry according to ISO 10 208, the 0.2% yield strength, the tensile strength and the elongation at maximum load (A_{gt}).

In addition, during the thread rolling, the thread dimensions must be controlled on each steel tendon, e.g. with thread gauges.

2.3.2.2 Anchor Nuts, Couplers and Anchor Plates

Anchor nuts, couplers and anchor plates must be provided with the sign of the manufacturer. The in-house production control must be carried out in the relevant fabricating plant.

2.3.2.2.1 Anchor Nuts

At least the following examinations must be carried out:

- Melting analysis according to the chemical composition filed with the German Institute for Civil Engineering.
- Tensile test performed on one nut with one steel tendon for each thermal treatment batch.

The test has been passed, if the steel tendon either breaks outside the anchorage and its influence zone or the ultimate load of the anchorage is at least equal to the nominal ultimate load of the steel tendon.

- From each thermal treatment batch 1% of all nuts, however, at least 10 nuts, are to be taken at random. On these nuts the dimensions including the thread dimensions must be controlled. If one nut is found with dimensions outside the permissible variation, all nuts of the thermal treatment batch must be controlled with regard to their dimensions.
- On 0.5% of all nuts, however, at least 5 nuts per thermal treatment batch, the Brinell hardness is to be determined. If one nut is found with a non condition related Brinell hardness, the thermal treatment batch must be blocked and the reason for the non condition related Brinell hardness clarified. The thermal treatment batch may only be released by the head of the quality department.
- All nuts must be visually inspected with regard to externally visible faults.

2.3.2.2.2 Couplers

Evidence of the material properties of the basic material must be produced with inspection certificate "3.1.B" in accordance with DIN EN 10 204:1995-08.

The examination must be carried out separately for melting charges. The applicant must carry out the following examinations:

- On 1% of all couplers, however, at least on 10 couplers per batch, the dimensions including the thread dimensions must be controlled. If one coupler is found with dimensions outside the permissible variation, all couplers of the batch must be controlled with regard to their dimensions.
- All couplers must be visually inspected with regard to externally visible faults.
- For each 2000 couplers, however, at least on 2 couplers per batch, the load capacity of the coupler splice is to be checked by means of a tensile test on a coupler splice consisting of 2 tendon sections and one coupler.

The test has been passed, if a steel tendon either breaks outside the coupler splice and its influence zone or if the ultimate load of the coupler splice is at least equal to the nominal ultimate load of the steel tendon.

2.3.2.2.3 Anchor plates

Evidence of the material properties of the basic material must be produced with inspection certificate "3.1.B" in accordance with DIN EN 10 204:1995-08.

On 1% of all plates, however, at least on 10 plates per charge, the dimensions must be controlled.

If one plate is found with dimensions outside the permissible variation, all plates of the batch must be controlled with regard to their dimensions.

In addition, each anchor plate must be visibly inspected with regard to gross faults by means of a yes/no check.

2.3.2.3 Spacers

From each batch 1% of all spacers, however, at least 10 spacers must be taken at random. On these spacers the dimensions according to Appendix 4 must be controlled (no recordings required).

2.3.3 External Surveillance

The in-house production control in each fabricating plant must be regularly checked, at least twice per year, by an external surveillance agency.

Within the scope of the external surveillance the first testing of the building product must be carried out. Also samples for sampling inspections must be taken and the inspection tools controlled. Samplings and inspections are incumbent on the relevant recognized inspection agency.

The results of the certification and external surveillance must be kept for at least five years. On request, they must be presented to the German Institute for Civil Engineering and the competent supreme construction supervision authority by the certification institution or inspection agency.

3 Provisions for Planning and Design

3.1 General

For the planning and design of structures using soil nails the following provisions must apply:

3.2 Internal and External Stability of the Nailed Soil Body

The following stability tests must be carried out:

- Slide stability within and underneath the nailed soil body as specified by DIN 1054 (see Figure 1, Appendix 1),
- evidence that the force resulting from constant loads cuts the sole area in its core (stability against tilting; see Figure 1, Appendix 1),
- ground failure safety (see Figure 1, Appendix 1): evidence must be produced in accordance with DIN 4017,
- testing of the sliding body (see Figure 2, Appendix 1).

The least favourable position of the sliding line is to be determined by variation of angle ϑ , contrary to DIN 4048. Active loads from soil pressure, the weight of the nailed soil body and external loads must be taken into account in the sliding bodies to be varied. These loads are counteracted by resistive forces from friction and cohesion in the sliding line as well as restraining forces of the nail sections located outside the sliding body (cf. section 3.3).

The counteraction of resistive and active loads must result in a safety factor of

$$\eta \geq 2.0 \text{ (load case 1)}$$

$$\eta \geq 1.5 \text{ (load case 2)}$$

If evidence is produced in accordance with the Fellenius rule

$$\eta_r = \frac{\tan cal\varphi}{\tan erf\varphi}$$

the safety factor is

$$\eta_r \geq 1.4 \text{ (load case 1)}$$

$$\eta_r \geq 1.3 \text{ (load case 2).}$$

These examinations are to be carried out for

- the Construction levels significant for stability based on the safety requirements of load case 2,
- the final state of the structure with regard to the base joint (resp. for sliding bodies starting from the base joint) and with regard to the intermediate joints significant for stability (or sliding bodies starting from them) based on the safety requirements of load case 1.

For low-lying joints, additionally evidence of the

- stability against gliding as required by DIN 1054 and
- safety against failure of the ground as stipulated by DIN 4084

must be produced, if the ground underneath the nailed soil body has lower shear strengths. If necessary, these evidences must also be produced for construction levels.

3.3 Verification of the Nails

The evidence which results in the greatest nail loads is decisive for the dimensioning of the nails. For this purpose, the following examinations must be carried out:

- Load portions in the nails based on the testing of the sliding body for final state or construction levels (see section 3.2),
- load portions in the nails from the active soil pressure on the facing (see section 3.4).

Evidence must be produced that a nail force of 131 kN (= yield load/1.75) is not exceeded and that loads from the nail can be transferred with a safety factor of 2.0 (see section 4.7) into the ground.

The following values must be assumed:

- yield load: 230 kN
- ultimate capacity: 280 kN

When calculating the nail forces, it must be demonstrated that the change of force in the steel tendon due to frequently repetitive live loads (including wind) based on the dynamic behavior of the air-side anchorage and the splices in the steel tendon does not exceed a value of 22 kN.

3.4 Facing

The soil pressure acting on the facing from the nailed soil body may be assumed to be 0.85 times the value of the active soil pressure in accordance with Coulomb's theory, but without taking into account any cohesion. The active soil pressure may be calculated as a rectangular distribution. Even if the soil is stratified, the overall soil pressure may be considered to be uniform. Active soil pressures from local loads and loads from ground anchors must not be reduced. The wall friction angle is specified with $\delta = 0$.

The dimensions of the facing must comply with DIN 1045. Near the nail heads, evidence against punching and partial pressure must be produced in accordance with DIN 1045.

3.5 Deformations

Horizontal movements of 2 ‰ to 4 ‰ of the wall height have been measured for this type of construction in tests under dead loads. In those tests the lengths of the nails were 0.5 to 0.7 times of the wall height. If the deformations must be restricted, the safety factors defined in section 3.2 must be increased.

In addition, the following reliable deformation values must be considered for the coupling joints or end anchorages of the soil nails:

- slip: 0.5 mm for each coupling joint or end anchorage,
- indentation of the domed plate: 5 mm.

(These values are valid for a permissible nail load of 131 kN.)

4 Provisions for Installation

4.1 General

The soil nails may only be installed under the technical supervision of DYWIDAG-Systems International GmbH. The soil nails may also be installed by companies which can present a certificate of DYWIDAG-Systems International GmbH that they have been thoroughly trained in the production of soil nails in accordance with this approval certificate. The executing company must declare that the DYWIDAG Soil Nailing System with Hollow Core Anchors Type R32N produced by it complies with the provisions of this approval certificate.

4.2 Drilling activities

The boreholes are drilled without a casing with a lost drill bit which is screwed on the steel tendon (see also Appendix 3). A water-cement suspension with a water/cement ratio of 0.7 is to be used as the flushing and supporting suspension. The water-cement suspension must be fed into the borehole through the steel tendon (steel pipe). During drilling the flushing and supporting suspension must exit at the borehole mouth.

If the desired depth has been reached, please proceed according to section 4.3.2.

The boreholes are to be drilled with a minimum inclination of 10° to the horizontal line.

For the maximum torque moment, the maximum impact impulse and the corresponding maximum impact energy in dependence of the drilling equipment used, the following threshold values must be observed:

- For a maximum torque moment of 280 Nm a maximum impact impulse of 45 kg m/s with a maximum impact energy of 220 J may be applied.
- For a maximum torque moment of 500 Nm a maximum impact impulse of 40 kg m/s with a maximum impact energy of 170 J may be applied.

4.3 Cement Grout for Injecting Boreholes

4.3.1 Composition

The basic materials for the cement grout are cements with special characteristics in accordance with DIN 1164:2000-11 and the following normal cements according to DIN EN 197-1:2001-02, water according to DIN EN 447 indicated in table 1, as well as approved reagents and concrete aggregates with a maximum particle size of 4 mm in accordance with DIN 4226-1. The water cement value must be between 0.35 and 0.50; in particular in cohesive soils the lowest possible value must be chosen. The cement grout must be mixed mechanically, and must not segregate and lump before its injection.

Table 1: Normal cements according to DIN EN 197-1:2001-02

Main cement type	Description of the normal cement type	
CEM I	Portland cement	CEM I
CEM II	Portland slag cement	CEM II/A-S
		CEM II/B-S
	Portland pozzolanic cement	CEM II/A-P
		CEM II/B-P
	Portland flue ash cement	CEM II/A-V
	Portland slate cement	CEM II/A-T
		CEM II/B-T
	Portland limestone cement	CEM II/A-LL
Portland composite cement	CEM II/B-M (S-V)	
CEM III	Blast furnace slag cement	CEM III/A
		CEM III/B

4.3.2 Injection of the Boreholes

After the desired depth has been reached (see section 4.2), grouting (according to section 4.3.1) must be performed until the grouting has driven out the supporting suspension and exits at the borehole mouth.

During injection the store tanks for the cement suspension may not be pumped empty, so that no air gets into the grouting.

4.4 Facing

Excavated areas must be protected by a facing without delay. For strongly expanding soils and/or construction projects for which deformations have to be kept to a minimum, wall reinforcements must be put in place in advance prior to the excavation (e.g. piles, pre-injections), if required.

The facing may consist of shotcrete or precast concrete elements. The shotcrete must at least correspond to the strength class of C25/30. DIN 18 551 applies to the manufacture and testing.

An adequate drainage must be provided so that no water pressure builds up behind the facing.

4.5 Anchoring of the Soil Nails on the Facing

To anchor the soil nails on the facing, anchor plates (see section 2.1.3) must be placed vertical to the tendon in fresh shotcrete or in a mortar bed. The borehole must be injected up to the front edge of the wall; the remaining hollow space caused by the inclined position of the nail must be filled with shotcrete. After hardening of the shotcrete shell, the nuts are to be fastened by hand.

4.6 Coupler Splices

The distance between the joints must be at least 1 m. To gain a sufficient self-locking between the steel tendon and the coupler, the ends of the steel tendon must be tensioned against each other when coupled with a torque of at least 300 Nm. For this purpose, a calibrated torque wrench is to be used. The torque moment may also be applied by the slewing gear of the drilling equipment, whereby the portion of the steel tendon already in the borehole is attached to the drill rig by means of a hydraulic clamping fixture. In this case the torque moment is controlled via the working pressure of the drill hammer used; it may not exceed 500 Nm.

4.7 Tests

4.7.1 Test Loadings

The mathematical working load F_w of the soil nail assumed in the soil mechanic analysis must be verified by test loadings. The test loadings must be performed on at least 3% of all nails or on 3 nails per soil type. For construction projects with less than 100 nails at least 5% of the nails, but at least 3 nails, are to be subjected to a test loading.

During the test loading a tensile force is to be applied to the nail head in steps of 20 kN up to the maximum test load of 2 times the working load F_w . If the forces in the steel tendons provided for the nailed soil body exceed a value of 207 kN (= 90% of the yield load), nails with a higher load-bearing capacity, but with the same soil-bond characteristics are to be used for the test loadings. During the test loading, which must be kept constant, the displacements must be read after 1, 2, 5, 10 and 15 minutes. The observation period must be prolonged, if the displacement Δs exceeds 0.5 mm between 5 and 15 minutes. In such cases observation must be continued until Δs is = 1.0 mm over a time interval of t_1 to $t_2 = 10 t_1$. Provided that one of the conditions is fulfilled for all nails tested, evidence of an adequate load-bearing capacity in the soil is produced. Care is to be taken during the test loading to ensure that the nail is not supported by the facing.

4.7.2 Group Effect

If the distance between the nails is less than about 0.8 m, the mutual effect due to the group loading is examined by subjecting at least 4 directly adjacent nails to a load.

5 Provisions for Usage, Support and Maintenance

5.1 Re-Checks

If the structure is subjected to special requirements with regard to deformations, re-checks – deformation measurements – must be performed after the soil nailing has been carried out. The necessity for this can be measured from the type of structure and/or the in-situ soil, taking into account public safety and order. The decisions related to the necessity for, the scope and duration of and the intervals between the deformation measurements are to be made based on the design data in consultation with the commissioned expert in earth construction and foundation engineering.

Henning

Certified by

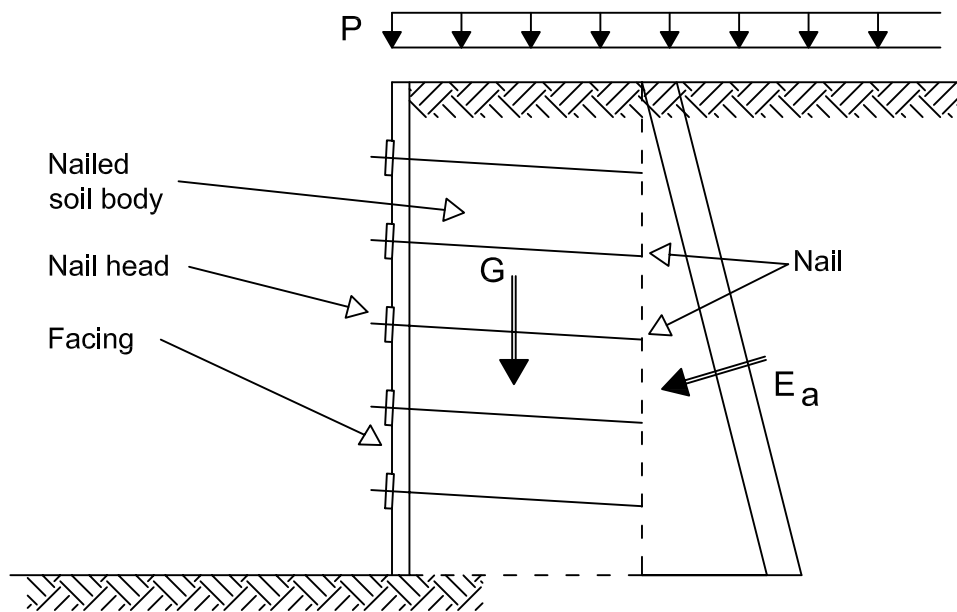

Fig. 1: Stability investigation on the total system

Estimate of the loads for verification of the resistance to slip, tilt and ground failure (shown for foundation joint).

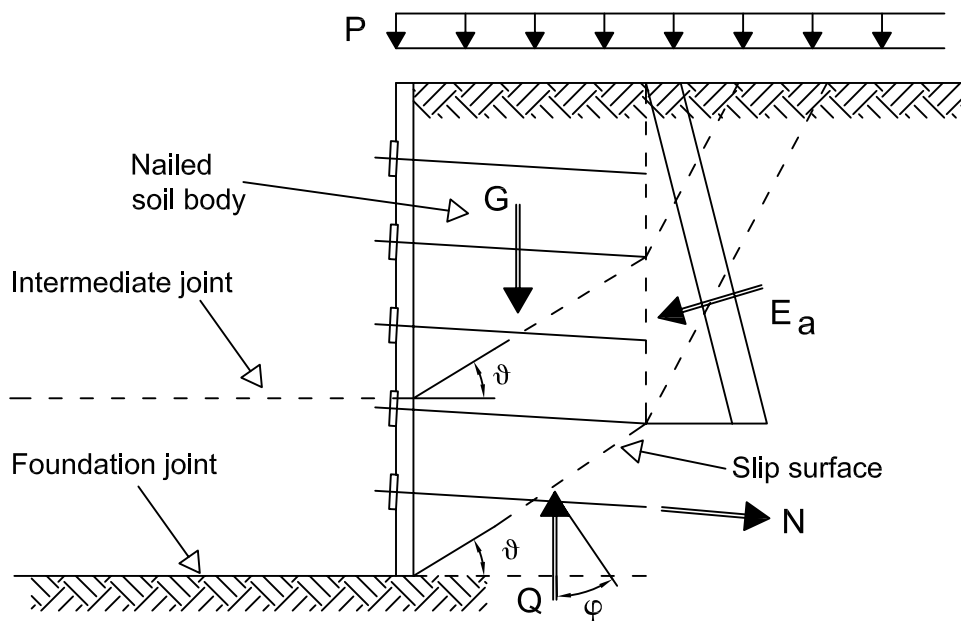

Fig. 2: Sliding body investigation

Determination of the least favourable slip surface by variation of the angle ϑ in the foundation joint and in the intermediate joints.

**DYWIDAG
SYSTEMS
International**

**DYWIDAG Soil Nailing
with hollow bars**

**Stability investigation and
sliding body investigation**

Appendix 1
to the general
German approval
Z-34.13-208 of
2004-April-21

Geometry of the steel tendon

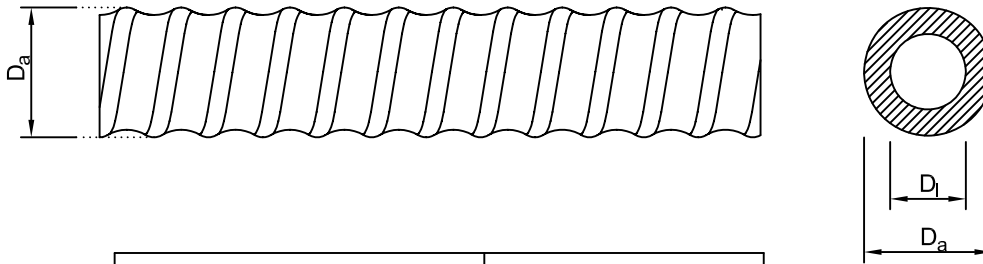

Bar type		R32N
Outer diameter *	D_a	32 mm
Inner diameter *	D_i	18.5 mm
Cross sectional area *	A_s	420 mm ²
Weight *		3.3 kg/m
Thread acc. to		ISO 10208
Material (Material-standard)		28 Mn 6 (DIN EN 10083-1)

* nominal values

The bars are rolled with a continuous left hand thread acc. to ISO 10208
Thread parameters (e.g. pitch) and tolerances acc. to ISO 10208

Material properties of the steel tendon

0.2% proof load	> 230 kN
Ultimate load	> 280 kN
Admissible nail load	131 kN (= 230 kN / 1.75)
0,2%-proof stress	approx. 550 N/mm ²
Ultimate stress	approx. 670 N/mm ²
Modulus of Elasticity	200,000 N/mm ²
Admissible dynamic load range	22 kN
Elongation at max. load A_{gt}	approx. 7 %

DYWIDAG
SYSTEMS
International

DYWIDAG Soil Nailing
with hollow bars

Geometry and material
properties of the steel tendons

Appendix 2

to the general
German approval
Z-34.13-208 of
2004-April-21

Nail with domed plate

Nail with flat plate

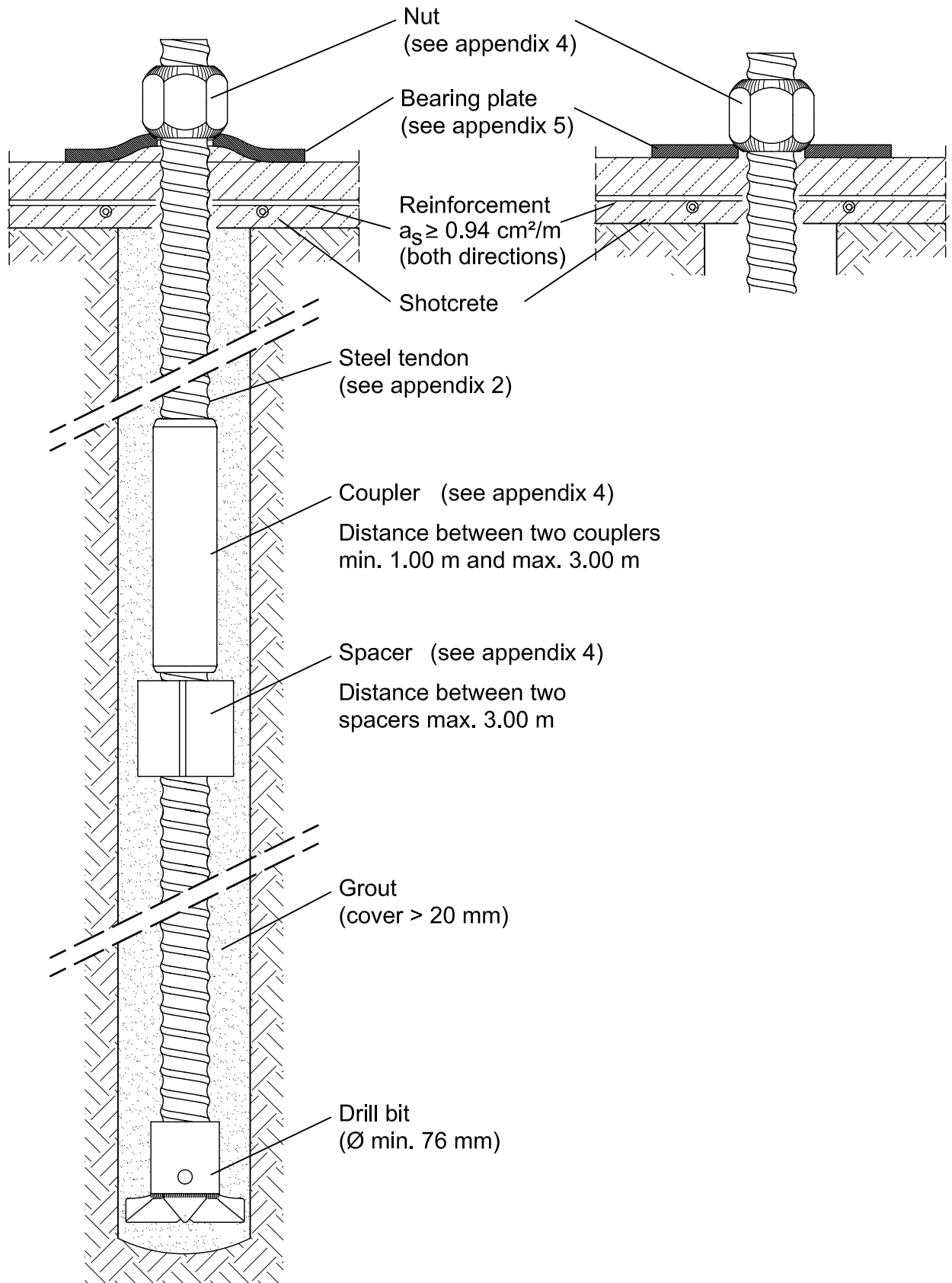

DYWIDAG
SYSTEMS
International

DYWIDAG Soil Nailing
with hollow bars

Temporary hollow core anchors
System "DYWIDAG"

Appendix 3

to the general
German approval
Z-34.13-208 of
2004-April-21

Coupler Material: 28Mn6 acc. to DIN EN 10083-1

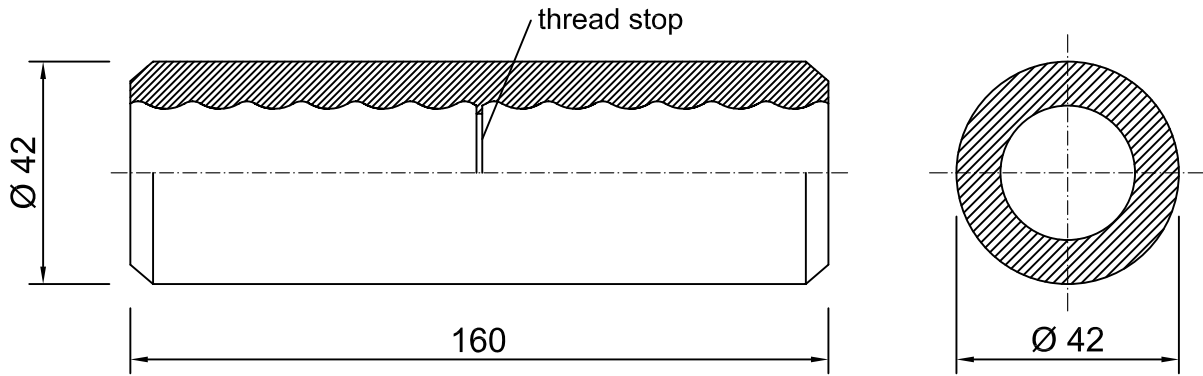

Anchor nut Material: GS 34CrMo4 acc. to DIN 17 205

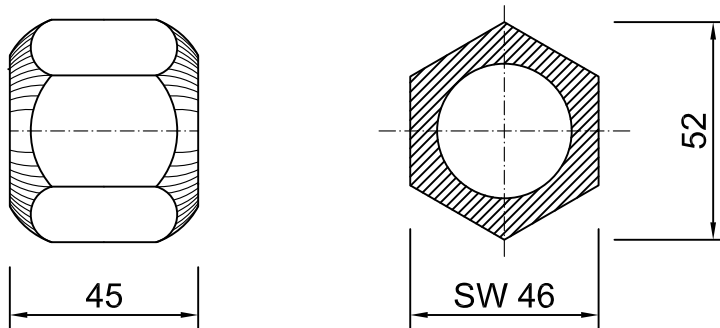

Spacer Material: GS 34CrMo4 acc. to DIN 17 205
 (alternative: EN-GJS-500-7 acc. to DIN EN 1563)

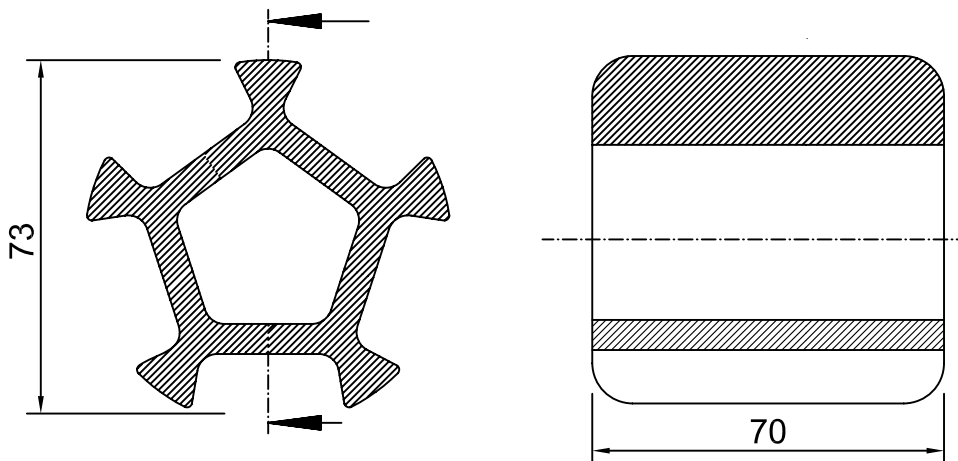

**DYWIDAG
 SYSTEMS
 International**

**DYWIDAG Soil Nailing
 with hollow bars**

**Accessories for
 DYWIDAG-hollow core anchors**

Appendix 4
 to the general
 German approval
 Z-34.13-208 of
 2004-April-21

Bearing plate (standard) Material: S235 (St37) acc. to DIN EN 10025

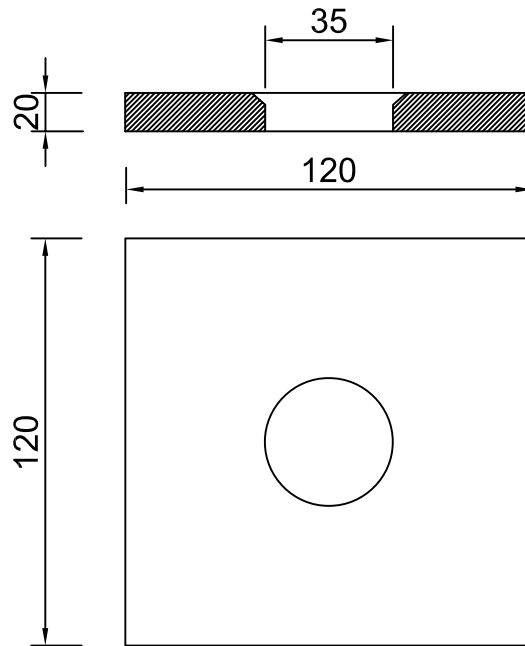

Domed plate

Material: S235 (St37) acc. to DIN EN 10025

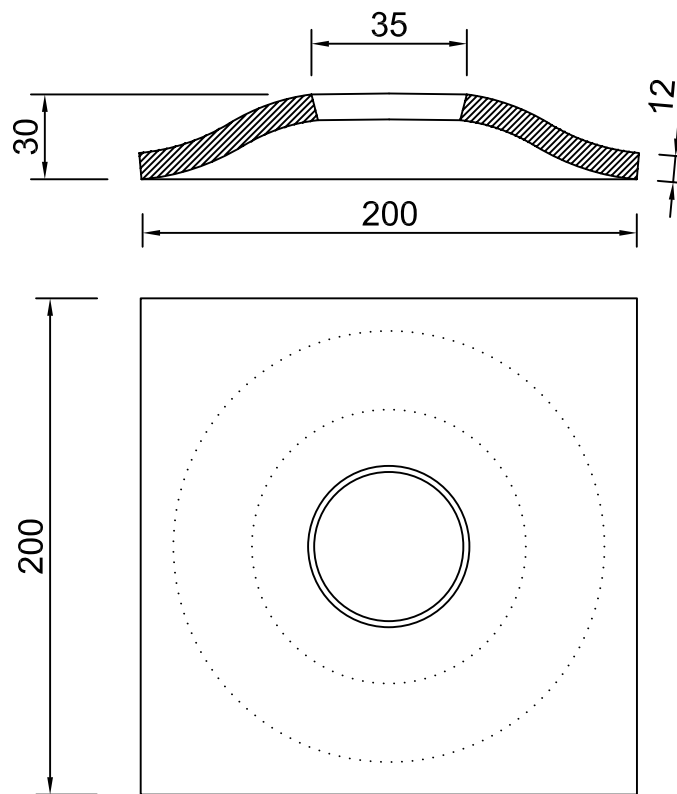

DYWIDAG
SYSTEMS
International

DYWIDAG Soil Nailing
with hollow bars

Bearing plates for
DYWIDAG-hollow core anchors

Appendix 5
to the general
German approval
Z-34.13-208 of
2004-April-21

Austria

DYWIDAG-Systems International GmbH
Alfred-Wagner-Strasse 1
4061 Pasching/Linz, Austria
Phone +43-7229-610 49 0
Fax +43-7229-610 49 80
E-mail dsi-a@dywidag-systems.at
www.dywidag-systems.at

Belgium and Luxembourg

DYWIDAG-Systems International N.V.
Industrieweg 25
3190 Boortmeerbeek, Belgium
Phone +32-16-60 77 60
Fax +32-16-60 77 66
E-mail info@dywidag.be
www.dywidag-systems.com

France

DSI-Artéon
146 Avenue du Bicentenaire
Z.I. Dagneux
01122 Montluel Cedex, France
Phone +33-4-78 79 27 82
Fax +33-4-78 79 01 56
E-mail dsi.france@dywidag.fr
www.dywidag-systems.fr

Germany

DYWIDAG-Systems International GmbH
Schuetzenstrasse 20
14641 Nauen, Germany
Phone +49-3321-44 18 0
Fax +49-3321-44 18 38
E-mail suspa@dywidag-systems.com
www.dywidag-systems.de

DYWIDAG-Systems International GmbH
Max-Planck-Ring 1
40764 Langenfeld, Germany
Phone +49-2173-79 02 0
Fax +49-2173-79 02 20
E-mail suspa@dywidag-systems.com
www.dywidag-systems.de

DYWIDAG-Systems International GmbH
Germanenstrasse 8
86343 Koenigsbrunn, Germany
Phone +49-8231-96 07 0
Fax +49-8231-96 07 40
E-mail suspa@dywidag-systems.com
www.dywidag-systems.de

DYWIDAG-Systems International GmbH
Siemensstrasse 8
85716 Unterschleissheim, Germany
Phone +49-89-30 90 50 100
Fax +49-89-30 90 50 120
E-mail dsihv@dywidag-systems.com
www.dywidag-systems.com

Italy

DYWIT S.P.A.
Via Grandi, 64
20017 Mazzo di Rho (Milano), Italy
Phone +39-02-934 68 71
Fax +39-02-934 68 73 01
E-mail info@dywit.it
www.dywit.it

Netherlands

DYWIDAG-Systems International B.V.
Veilingweg 2
5301 KM Zaltbommel, Netherlands
Phone +31-418-57 89 22
Fax +31-418-51 30 12
E-mail email@dsi-nl.nl
www.dywidag-systems.com

Norway

DYWIDAG-Systems International AS
Industrievieien 7A
1483 Skytta, Norway
Phone +47-67-06 15 60
Fax +47-67-06 15 59
E-mail adm@dsi-dywidag.no
www.dywidag-systems.com

Poland

DYWIDAG-Systems International Sp. z o.o.
ul. Przywidzka 4/68
80-174 Gdansk, Poland
Phone +48-58-300 13 53
Fax +48-58-300 13 54
E-mail dsi-polska@dywidag-systems.com
www.dywidag-systems.pl

Spain

DYWIDAG Sistemas Constructivos, S.A.
Avd/de la Industria, 4
Pol. Ind. la Cantuena
28947 Fuenlabrada (Madrid), Spain
Phone +34-91-642 20 72
Fax +34-91-642 27 10
E-mail dywidag@dywidag-sistemas.com
www.dywidag-sistemas.com

United Kingdom

DYWIDAG-Systems International Ltd.
Northfield Road
Southam, Warwickshire
CV47 0FG, Great Britain
Phone +44-1926-81 39 80
Fax +44-1926-81 38 17
E-mail sales@dywidag.co.uk
www.dywidag-systems.com/uk

AUSTRIA
ARGENTINA
AUSTRALIA
BELGIUM
BOSNIA AND HERZEGOVINA
BRAZIL
CANADA
CHILE
COLOMBIA
COSTA RICA
CROATIA
CZECH REPUBLIC
DENMARK
EGYPT
ESTONIA
FINLAND
FRANCE
GERMANY
GREECE
GUATEMALA
HONDURAS
HONG KONG
INDONESIA
ITALY
JAPAN
KOREA
LEBANON
LUXEMBOURG
MALAYSIA
MEXICO
NETHERLANDS
NORWAY
OMAN
PANAMA
PARAGUAY
PERU
POLAND
PORTUGAL
QATAR
SAUDI ARABIA
SINGAPORE
SOUTH AFRICA
SPAIN
SWEDEN
SWITZERLAND
TAIWAN
THAILAND
TURKEY
UNITED ARAB EMIRATES
UNITED KINGDOM
URUGUAY
USA
VENEZUELA