

GEWI® Threadbar System

High Yield Steel for Reinforcement of Concrete







<i>GEWI®</i> Threadbar System	4
Technical Data for the <i>GEWI®</i> Threadbar	4
Couplers for <i>GEWI®</i> Threadbars	5
Anchorage for <i>GEWI®</i> Threadbars.....	5
<i>GEWI®</i> Threadbar Accessories	6
Corrosion Protection	6
<i>GEWI®</i> Threadbar – Connecting Reinforcement	7
<i>GEWI®</i> Threadbar – Prefabricated Connecting Reinforcement	8
<i>GEWI®</i> Threadbar – Typical Applications for Reinforcing Concrete.....	10
<i>GEWI®</i> Threadbar – Further Applications	10
<i>GEWI®</i> Threadbar – Mounting Connecting Reinforcement.....	11
<i>GEWI®</i> Threadbar – Assembly Instructions for Couplers	11



GEWI® Threadbar System

Key features of the system are:

- Fully threaded bar – can be cut and coupled at any point.
- Robust threadform – ideal for construction site use.
- Coarse pitch threadform with two flats – ensures self-cleaning of thread.
- Fully galvanized systems – galvanized threadbars and accessories also available from stock.

The GEWI® Threadbar System consists of high yield GEWI® screwable steel and corresponding coupling and anchoring accessories, which enable easy connections to and anchorages of GEWI® steel. In accordance with the German certificates of approval Z-1.5-76, Z-1.5-149 and Z-1.5-2.

GEWI® Steel High Yield Threadbar is a high tensile alloy steel bar which features a coarse right-hand thread over its full length. The system is proven worldwide and offers versatility in a range of applications.

Manufactured in accordance with the German Certificate of Approval issued by the Deutsches Institut für

Bautechnik, the system also offers general conformance with BS 4449 : 1997 (Carbon Steel Bars for Prestressing of Concrete).

The minimum specified characteristic yield strength is 500N/mm² for bar diameters 16 - 50mm and 555N/mm² for the 63.5mm diameter bar.

16 - 50mm bars can be welded using appropriate industry practices relative to the carbon content of the steel. Welding of the higher grade 63.5mm diameter bar is not recommended.

Technical Data for the GEWI® Threadbar

GEWI® Bar Diameter	Steel Grade Yield f_y /Tensile Strength f_t ¹⁾	Ultimate Tensile Force F_t ^(a)	Yield Force F_y	Cross Sectional Area	Diameter over Threads	Bar Weight
[mm]	[N/mm ²]	[kN]	[kN]	[mm ²]	[mm]	[kg/m]
16	500/550	111	100	210	19	1.58
20	500/550	173	157	314	23	2.47
25	500/550	270	245	491	29	3.85
28	500/550	339	308	616	32	4.83
32	500/550	442	402	804	36	6.31
40	500/550	691	628	1257	45	9.87
50	500/550	1080	982	1963	56	15.40
63.5	555/700	2219	1758	3167	69	24.80

¹⁾ GEWI® Threadbars also meet the requirements according UK standard (500/600 N/mm²) and Austrian standard (550/620 N/mm²).

^(a) For geotechnical applications, 75% of the ultimate tensile force F_t may be used for testing

Modulus of elasticity: $E = 205,000\text{N/mm}^2 \pm 5\%$.

Stock lengths: All bar diameters 12.0m. Tolerances $\pm 100\text{mm}$. Special lengths up to 15.0m can be ordered.

All bar diameters can be cut to length to suit customer requirements, or can be supplied bent.

Couplers for GEWI® Threadbars

Couplers allow GEWI® Threadbars to be coupled or extended reliably and efficiently. The choice of the type of coupler used depends on the application.

The static coupler is used either in constant tension applications or in a combination of tension and compression loading. The longer dynamic couplers are to be used when

vibration and cyclical load reversals are anticipated. Lock nuts must be used at each end of the couplers. Torqued to a predetermined value, they prevent the development of cracks in structural concrete.

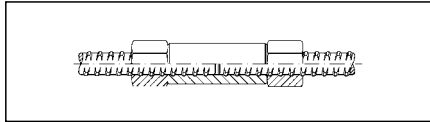

Static Coupler

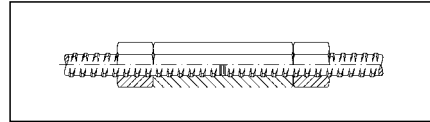

Dynamic Coupler

Coupler strength = 1.3 x Yield Strength of the bar in accordance with German Approval Certificates. According to UK Standards, this equates to 1.08 of Ultimate Strength.

For the connection of GEWI® Threadbars with different diameters,

special transition couplers are available. In addition, DSI provides solutions for

connecting fixed and therefore not pivotable GEWI® bars.

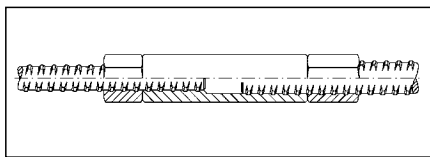

Transition Coupler

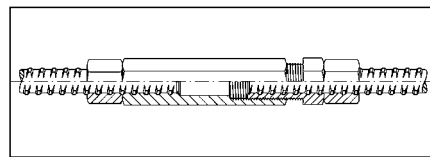

Tensioning Coupler

For couplers exposed to compression load, predominately in geotechnical applications, lock nuts can be omitted.

However it is important that the two threadbars meet centrally within the coupler and remain so during installation to ensure a correct load transfer.

This can be achieved by using grub screws and a center pin. The right position of the GEWI® Threadbars within the coupler can be checked easily using colored marks.

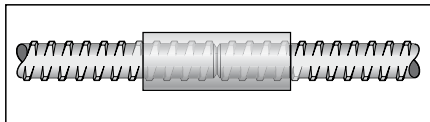

Standard Coupling

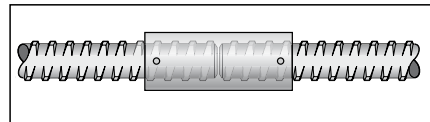

Grub Screws – Optional

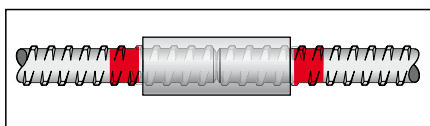

Paint – Visual Indicator

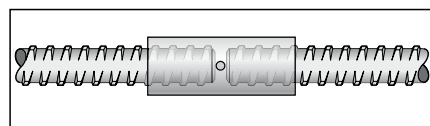

Center Pin – Optional

Anchages for GEWI® Threadbars

Anchages which are to be embedded in concrete can be carried out using an anchor nut (hexagonal nut), a steel plate and a lock nut.

In addition, an anchorage can be realized using a flanged nut and a lock nut.

For the connection of GEWI® Threadbars with steel structures, a weldable anchor piece is available.

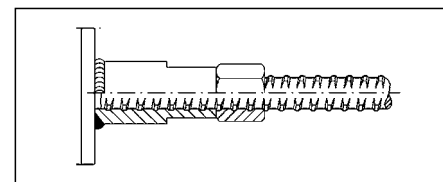
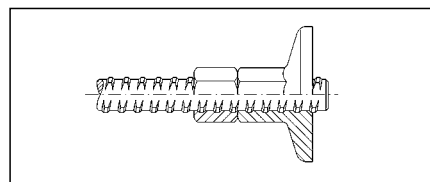
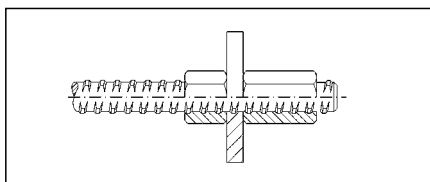

GEWI® Threadbar Accessories

Nominal Diameter	Flat Plate Stock Size *	Hexagonal Nut		Recessed Plate Stock Size *	Domed Nut		Formed Plate Stock Size *	Hemisphere	
		AF	Length		AF	Length		Dia.	Length
[mm]	[mm]	[mm]	[mm]	[mm]	[mm]	[mm]	[mm]	[mm]	[mm]
16	150 x 150 x 10	32	40	150 x 150 x 30			150 x 150 x 10	46	18
20	150 x 150 x 10	36	45	150 x 150 x 30	35	41	150 x 150 x 10	46	18
25	150 x 150 x 10	41	50	150 x 150 x 30	38	45	150 x 150 x 10	57	23
28	150 x 150 x 10	46	55	200 x 200 x 40	43	54	150 x 150 x 10	57	23
32	200 x 200 x 25	55	60	200 x 200 x 40	46	57		80	33
40	250 x 250 x 40	65	70	250 x 250 x 50				120	55
50	300 x 300 x 40	80	120	300 x 300 x 50				120	60

* Anchor plates can be supplied in any size to suit customer requirements.

Nominal Diameter	Static Coupler ^(a)		Static Coupler ^(a)		Dynamic Coupler ^(a)		Lock Nut		Flanged Anchor Nut		Torque M _T	
	Dia.	Length	Dia.	Length	Dia.	Length	AF	Length	AF	Length		Dia.
[mm]	[mm]	[mm]	[mm]	[mm]	[mm]	[mm]	[mm]	[mm]	[mm]	[mm]	[mm]	[Nm]
16	32	90	34	90	32	115	32	30	30	35	50	200
20	36	105	38	105	32	130	32	40	36	40	60	350
25	40	115	42	115	41	150	41	40	41	45	70	700
28	45	125	48	125	41	170	41	45	46	50	85	950
32	52	140	55	140	50	180	50	50	50	60	100	1600**
40	65	160	68	160	60	210	65	70	60	70	120	2900**
50	80	200	84	200	80	240	80	80	80	85	150	8000**
63.5	102	260	106	260	102	260	90	110	100	115	250	8000**

** Torque applied to lock nut using hydraulic torque wrench.

^(a) Cast coupler

^(b) Machined coupler

Plates	Flat Plate	Formed Plate up to 20°	Articulating Plate up to 30°	Gusseted Plate up to 45°
Nuts	Lock Nut	Hexagonal Nut	Flanged Nut	Domed Nut
Couplers	Static Coupler	Dynamic Coupler	Contact Coupler	Transition Coupler
Ancillaries	Mechanical Shell	Tapered Washer up to 15°	Hemisphere up to 30°	Lifting Shackle

Corrosion Protection

Galvanizing acc. to EN ISO 1461 : 1999

Rock Bolts

Soil Nails

Temporary Ground Anchors

Double Corrosion Protection acc. to BS 8081 : 1989

Permanent Soil Nails

Permanent Ground Anchors

GEWI® Threadbar – Connecting Reinforcement



The GEWI® connecting reinforcement consists of prefabricated GEWI® couplers for the use in construction joints.

The transmission of the forces of the construction joint to the reinforcement of the adjacent concrete takes place by bond.

The GEWI® connecting systems with straight reinforcement consist of coupler bars type M and coupler bars type A. These are provided in three standard lengths which cover the range of the required embedment length.

The GEWI® connecting bar type M is to be fixed to the formwork. For this purpose, special plugs are available which can be nailed on the formwork.

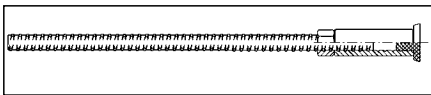

Coupler Bar Type M

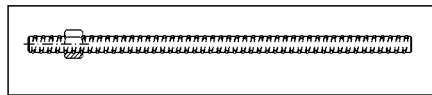

Coupler Bar Type A

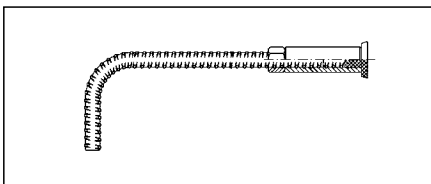

Hook Bar Type W

In case of lack of free space, can be shortened the connecting reinforcement by using:

- Hook Bar Type W
- Loop Bar Type S
- End Anchoring Bar Type E.

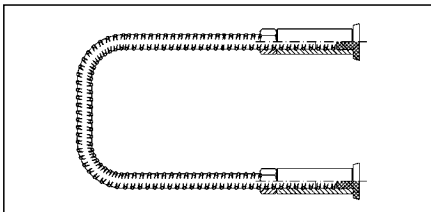

Loop Bar Type S

The GEWI® connecting bar type P is recommended when a load transmission through a reinforced concrete wall is to be realized.

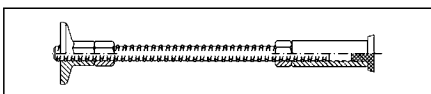

End Anchoring Bar Type E

These types of connecting reinforcement are not on stock and will be customized on demand.

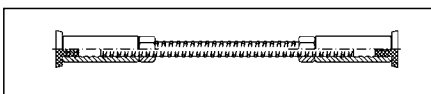

Connecting Bar Type P

GEWI® Threadbar – Prefabricated Connecting Reinforcement

Standard Lengths

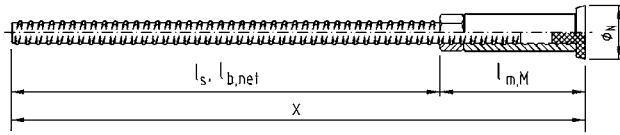

GEWI® Coupler Bar Type M

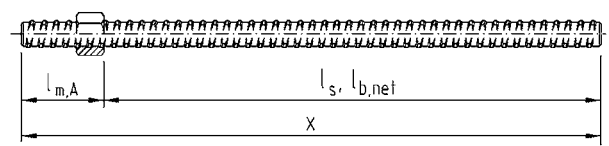

GEWI® Coupler Bar Type A

GEWI® Ø	Coupler Bar Type M		Lap Length	Weight	Total Length	Length of Coupler Part	Lock Nut Standard T 2003		Coupler Standard T 3003		Plug	
	Designation	$l_{b,net}$ [cm]					G [kg]	X [mm]	$l_{m,M}$ [mm]	AF [mm]	L_{Km} [mm]	Ø [mm]
12	GEWI-M12 -	36	36	0.53	445	85	19	20	22	60	40	5
		54	54	0.69	625							
		96	96	1.07	1045							
16	GEWI-M16 -	55	55	1.58	675	125	32	30	32	90	52	5
		102	102	2.32	1145							
		183	183	3.60	1955							
20	GEWI-M20 -	69	69	2.71	840	150	32	40	36	105	52	5
		128	128	4.16	1430							
		229	229	6.66	2440							
25	GEWI-M25 -	86	86	4.72	1020	160	41	40	42	115	62	5
		160	160	7.56	1760							
		286	286	12.42	3020							
28	GEWI-M28 -	97	97	6.62	1145	175	41	45	45	125	62	5
		179	179	10.58	1965							
		320	320	17.39	3375							
32	GEWI-M32 -	111	111	9.91	1308	198	50	50	52	140	60	8
		205	205	15.84	2248							
		366	366	26.00	3858							

GEWI® Ø	Coupler Bar Type A		Lap Length	Weight	Total Length	Length of Coupler Part	Lock Nut Standard T 2003	
	Designation	$l_{b,net}$ [cm]					G [kg]	X [mm]
12	GEWI-A12 -	36	36	0.40	410	50	19	20
		54	54	0.59	590			
		96	96	1.93	1010			
16	GEWI-A16 -	55	55	1.15	625	75	32	30
		102	102	1.89	1095			
		183	183	3.17	1905			
20	GEWI-A20 -	69	69	2.11	783	93	32	40
		128	128	3.57	1373			
		229	229	6.07	2383			
25	GEWI-A25 -	86	86	4.00	960	100	41	40
		160	160	6.85	1700			
		286	286	11.70	2960			
28	GEWI-A28 -	97	97	5.62	1078	108	41	45
		179	179	9.59	1898			
		320	320	16.40	3308			
32	GEWI-A32 -	111	111	8.41	1230	120	50	50
		205	205	14.34	2170			
		366	366	24.50	3780			

GEWI® Threadbar – Prefabricated Connecting Reinforcement

Customized Products

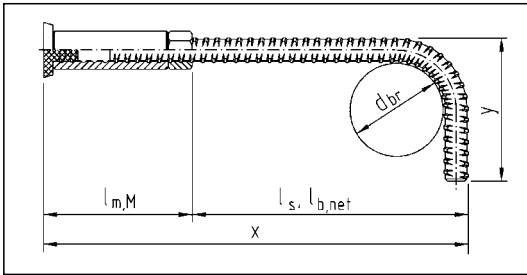

Hook Bar Type W

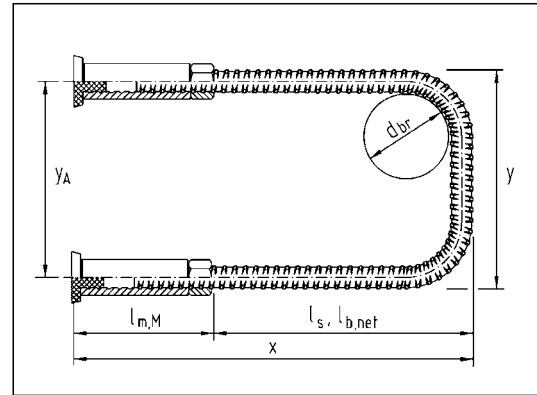

Loop Bar Type S

Specifications

GEWI® W \emptyset - $x/y/d_{br}$

- \emptyset diameter GEWI® BSt 500 S
- x total length
- y hook length
- d_{br} bending diameter

- $l_{b, net}$ anchorage length
- $l_{m, M}$ length of coupler part

Specifications

GEWI® S \emptyset - $x/y/d_{br}$

- \emptyset diameter GEWI® BSt 500 S
- x total length
- y loop width
- d_{br} bending diameter

- $l_{b, net}$ anchorage length
- $l_{m, M}$ length of coupler part
- y_A center distance

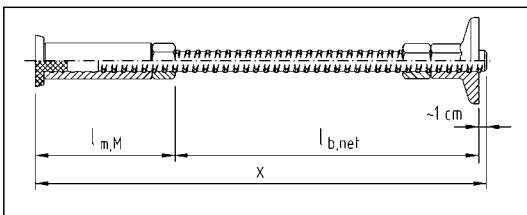

End Anchorage Bar Type E

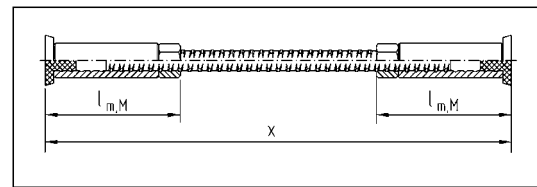

Connecting Bar Type P

Specifications

GEWI® E \emptyset - x

- \emptyset diameter GEWI® BSt 500 S
- x total length

Specifications

GEWI® P \emptyset - x

- \emptyset diameter GEWI® BSt 500 S
- x fitting length

GEWI® Threadbar – Typical Applications for Reinforcing Concrete

Examples for roof connections

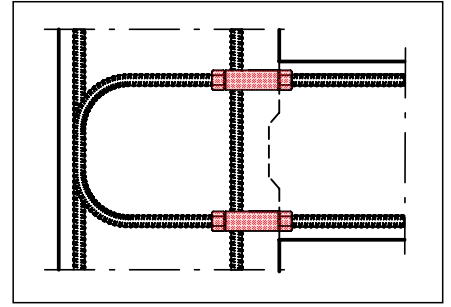
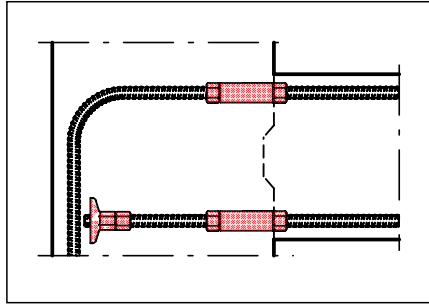
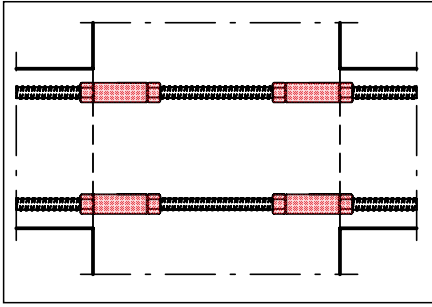

Examples for connecting bending reinforcement

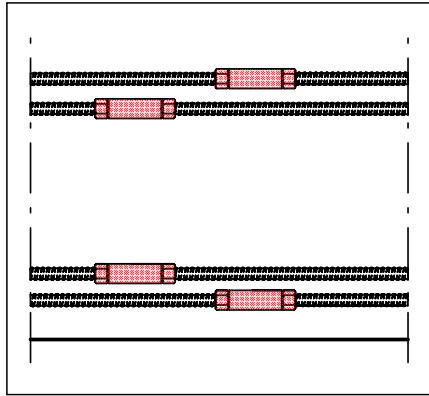
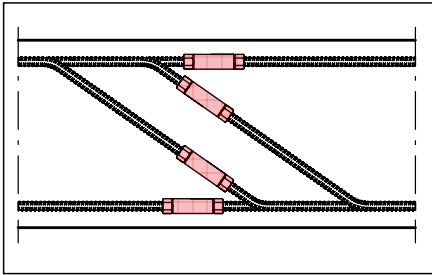

Example for a fixed column support

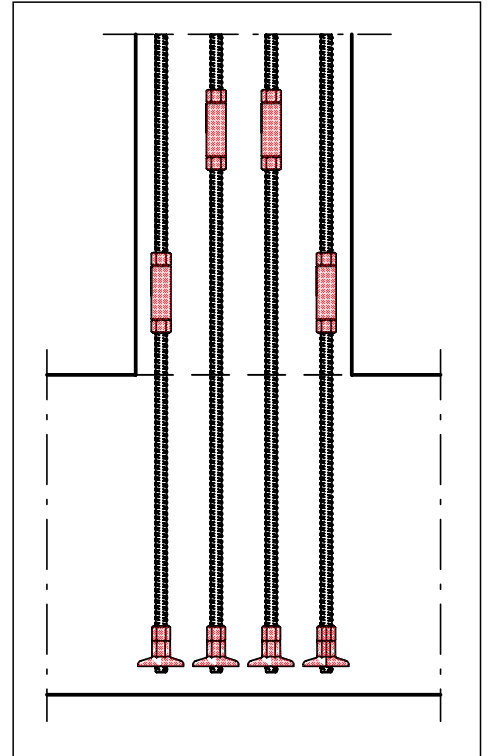

Examples for a frame corner and a consite

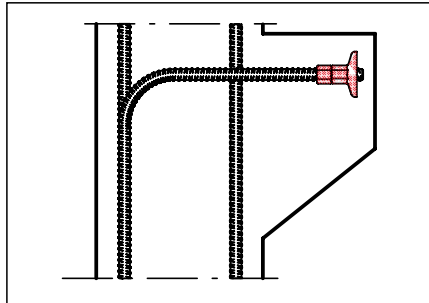
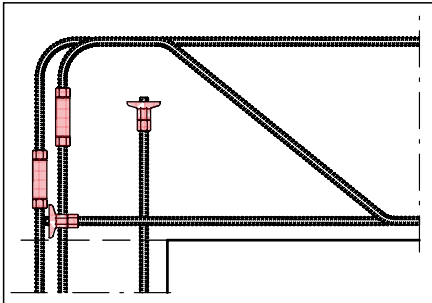

GEWI® Threadbar – Further Applications

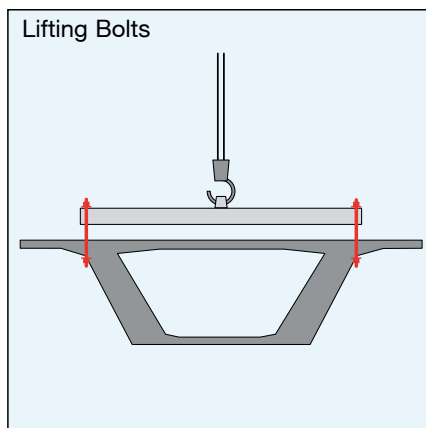
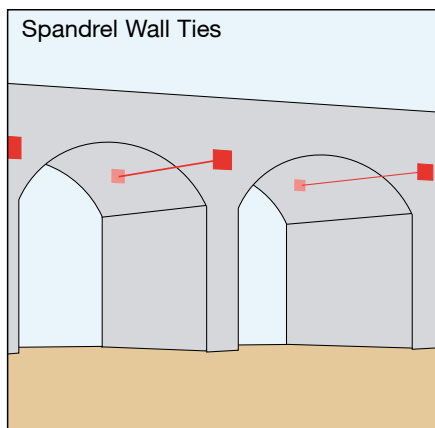

GEWI® Threadbar – Mounting Connecting Reinforcement

The GEWI® connecting reinforcement

- Coupler Bar Type M
- Loop Bar Type S
- Hook Bar Type W
- Anchoring Bar Type E
- Connecting Bar Type P

are delivered with a pre-mounted coupler and are to be fixed to the formwork prior concreting.

GEWI® Threadbar – Assembly Instructions for Couplers

The assembly of GEWI® coupler can be carried out fast and simple in the following way:

1. Marking of the screw-in length at the fifth rib to ensure the turn in of four ribs of the rod.
2. Screwing on a lock nut and a coupler on steel rod 1 and a lock nut on steel rod 2.
3. Joining the steel rods together and screwing up the coupler. Checking with the marking if both steel rods are turned in sufficiently into the coupler.
4. Hand-screwing the lock nuts against the coupler.
5. Locking the nut with the required torque using special torque wrenches.

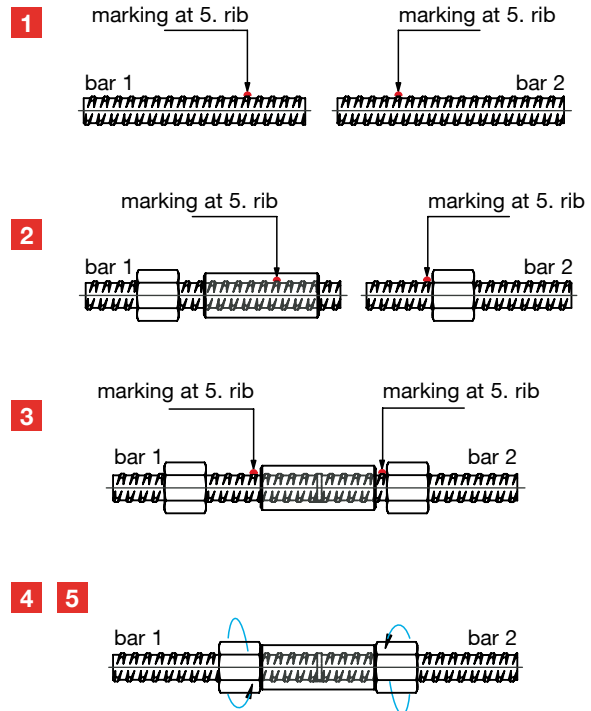

Installation procedure for the GEWI® connecting reinforcement

1. Nail the plug on the formwork in the desired position.
2. Screw on the GEWI® Coupler Bar Type M manually.
3. After the formwork has been demoulded, screw off the plug.
4. Screw in the GEWI® Coupler Bar Type A and lock it with the required torque.

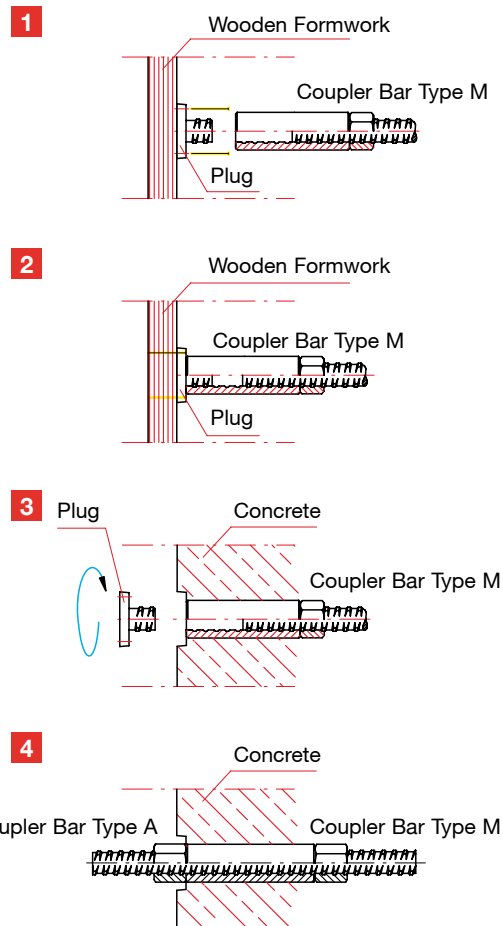

Austria

DYWIDAG-Systems International GmbH
 Alfred-Wagner-Strasse 1
 4061 Pasching/Linz, Austria
 Phone +43-7229-61 04 90
 Fax +43-7229-61 04 980
 E-mail: dsi-a@dywidag-systems.at
 www.dywidag-systems.at

Belgium and Luxembourg

DYWIDAG-Systems International N.V.
 Industrieweg 25
 3190 Boortmeerbeek, Belgium
 Phone +32-16-60 77 60
 Fax +32-16-60 77 66
 E-mail: info@dywidag.be

France

DSI-Artéon SAS
 Avenue du Bicentenaire
 ZI Dagneux-BP 50053
 01122 Montluel Cedex, France
 Phone +33-4-78 79 27 82
 Fax +33-4-78 79 01 56
 E-mail: dsi.france@dywidag.fr
 www.dywidag-systems.fr

Germany

DYWIDAG-Systems International GmbH
 Schuetzenstrasse 20
 14641 Nauen, Germany
 Phone +49-3321-44 18 32
 Fax +49-3321-44 18 18
 E-mail: suspa@dywidag-systems.com

DYWIDAG-Systems International GmbH
 Max-Planck-Ring 1
 40764 Langenfeld, Germany
 Phone +49-2173-79 02 0
 Fax +49-2173-79 02 20
 E-mail: suspa@dywidag-systems.com
 www.dywidag-systems.de

DYWIDAG-Systems International GmbH
 Germanenstrasse 8
 86343 Koenigsbrunn, Germany
 Phone +49-8231-96 07 0
 Fax +49-8231-96 07 40
 E-mail: suspa@dywidag-systems.com

Italy

DYWIT S.P.A.
 Via Grandi, 64
 20017 Mazzo di Rho (Milano), Italy
 Phone +39-02-93 46 87 1
 Fax +39-02-93 46 87 301
 E-mail: info@dywit.it
 www.dywit.it

Netherlands

DYWIDAG-Systems International B.V.
 Veilingweg 2
 5301 KM Zaltbommel, Netherlands
 Phone +31-418-57 89 22
 Fax +31-418-51 30 12
 E-mail: email@dsi-nl.nl

Norway

DYWIDAG-Systems International AS
 Industriveien 7A
 1483 Skytta, Norway
 Phone +47-67-06 15 60
 Fax +47-67-06 15 59
 E-mail: adm@dsi-dywidag.no

Poland

DYWIDAG-Systems International Sp. z o.o.
 ul. Przywidzka 4/68
 80-174 Gdansk, Poland
 Phone +48-58-300 13 53
 Fax +48-58-300 13 54
 E-mail: dsi-polska@dywidag-systems.com
 www.dywidag-systems.pl

Portugal

DYWIDAG-Systems International LDA
 Rua do Polo Sul
 Lote 1.01.1.1 - 2B
 1990-273 Lisbon, Portugal
 Phone +351-21-89 22 890
 Fax +351-21-89 22 899
 E-mail: dsi.lisboa@dywidag.pt

Spain

DYWIDAG Sistemas Constructivos S.A.
 Avenida de la Industria, 4
 Pol. Ind. la Cantuena
 28947 Fuenlabrada (Madrid), Spain
 Phone +34-91-642 20 72
 Fax +34-91-642 27 10
 E-mail: dywidag@dywidag-sistemas.com
 www.dywidag-sistemas.com

United Kingdom

DYWIDAG-Systems International Ltd.
 Northfield Road
 Southam, Warwickshire
 CV47 0FG, Great Britain
 Phone +44-1926-81 39 80
 Fax +44-1926-81 38 17
 E-mail: sales@dywidag.co.uk
 www.dywidag-systems.com/uk

AUSTRIA
 ARGENTINA
 AUSTRALIA
 BELGIUM
 BOSNIA AND HERZEGOVINA
 BRAZIL
 CANADA
 CHILE
 COLOMBIA
 COSTA RICA
 CROATIA
 CZECH REPUBLIC
 DENMARK
 EGYPT
 ESTONIA
 FINLAND
 FRANCE
 GERMANY
 GREAT BRITAIN
 GREECE
 GUATEMALA
 HONDURAS
 HONG KONG
 INDONESIA
 ITALY
 JAPAN
 KOREA
 LEBANON
 LUXEMBOURG
 MALAYSIA
 MEXICO
 NETHERLANDS
 NORWAY
 OMAN
 PANAMA
 PARAGUAY
 PERU
 POLAND
 PORTUGAL
 QATAR
 SAUDI ARABIA
 SINGAPORE
 SOUTH AFRICA
 SPAIN
 SWEDEN
 SWITZERLAND
 TAIWAN
 THAILAND
 TURKEY
 UNITED ARAB EMIRATES
 URUGUAY
 USA
 VENEZUELA

Please note:

This brochure serves basic information purposes only. Technical data and information provided herein shall be considered non-binding and may be subject to change without notice. We do not assume any liability for losses or damages attributed to the use of this technical data and any improper use of our products. Should you require further information on particular products, please do not hesitate to contact us.

www.dywidag-systems.com